

# TERRITORIAL NEWS



## INSIDE THIS ISSUE

PRESIDENT'S MESSAGE	1
WRBA 2013 DEALER TABLES	4
BLACK GLASS FACETED BALL BUTTONS	5
WRBA 2013 REGISTRATION	Insert
WRBA 2013 TRAY SLIPS & ENTRY FORM	Insert

Western Regional Button Association  
Volume 11, Number 2  
MAY 25, 2013

*The Pearlies were invited guests at the opening of the Olympics & will join us at WRBA 2013!!!!*



VISIT OUR WEB PAGE AT [WWW.WRBA.US](http://WWW.WRBA.US)

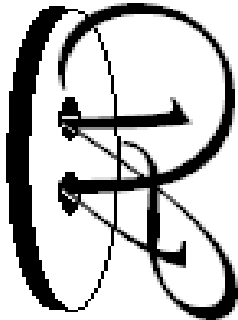

c/o C. Joy Journey, Editor  
4000 Truro Drive  
ANCHORAGE AK 99507

An interest that is not nurtured fades.  
Knowledge that is not shared dies  
with the mind of he who hoards it.  
A pleasure that is not shared is a  
feeble pleasure, indeed.

# WRBA Mission Statement

- ♥ Establish an affiliation, a forum, and an identity for all Western U.S. button collectors, including those who are not part of any local organization
- ♥ Unite the isolated collectors of the west with the established clubs
- ♥ Pool the talents and resources of members for enrichment of the hobby
- ♥ Keep us all in touch via the territorial newsletter
- ♥ Host a regional show with the purpose of:
  - Recruiting those fascinated by buttons into the hobby
  - Providing educational workshops & presentations
  - Learning through competition
  - Meeting dealers and obtaining buttons for our collections
  - Refreshing our interest and ambition in collecting
  - Enjoying the camaraderie and fun of gathering together

[www.wrba.us](http://www.wrba.us)

## WRBA BOARD

**President** Tom Barrans  
559 683-6418 tomdarby@sti.net  
P O Box 2556, Oakhurst CA 93644

**Vice President** Gil Biggie  
775 971-9538  
dbgb@charter.net  
9075 Wigwam Way, Reno NV 89506

**Secretary** Barbara Johnson  
360 893-0647 bljbuttons@juno.com  
718 Maple Lane SW  
Orting WASHINGTON 98360  
844 S 82nd Pl, Mesa AZ 85208 winter

**Treasurer** Susannah Jordan  
303 442-5511  
buttonsgrandmas@earthlink.net  
6623 Left Hand Canyon,  
Jamestown CO 80455

**Past President** Joy Journeay  
907 223-1040 joyjourneay@gmail.com  
4000 Truro Drive  
Anchorage, ALASKA 99507

**Show Chair** Joy Journeay  
See Past President listing above

**Web Chair** Mika Jarmusz  
503 371-0868 mikajz@comcast.net  
2845 "D" Street NE, Salem OR 97301

**Judging Chair** Barbara Barrans  
559 683-6418 darbysbarb@aol.com  
P O Box 2556, Oakhurst CA 93644

**Awards Chair** Tom Barrans  
See President listing above.

**Membership Chair** Harriett Brittenham  
720 851-2574 brittmh@aol.com  
6174 Saddlecreek Trail  
Parker CO 80134

**Education Chair** Fran Howell  
330 794-8119 fhowell@neo.rr.com  
251 Pfeiffer Avenue  
Akron OHIO 44312-1354

**Newsletter Editor** Joy Journeay  
See Past President listing above.

**Librarian** Judy Schwenk  
360.293.2315 anajamm@comcast.net  
5518 Sugarloaf Street  
Anacortes, WASHINGTON 98221

**At-Large Member** Roberta Schuler  
520 296-8196 bklassic@comcast.net  
6565 E. Crimson Sage Drive  
Tucson ARIZONA 85750-3163

**At-Large Member** Gloria Skovronsky  
360 452-1740 gloriosky999@aol.com  
1243 Township Line Road  
Port Angeles WA 98362

**Fundraising Chair** Vacant

## Membership

WRBA membership year is Jan-Dec.  
Save \$5 by joining for two years!

### Annual Two-Year

**Junior (ages 8 thru 17) ...\$5.....\$10**  
**Active member—print .... \$25.....\$45**  
 Black & white newsletters,  
 printed and mailed  
**Active member—email.... \$20.....\$35**  
 Color PDF newsletters,  
 sent via email  
**Dual membership..... \$30.....\$55**  
 \*residence at same address; one  
 newsletter sent in selected format  
**Life .....\$250**

Membership is required to receive the newsletter, compete in competition, or to vote and have a voice in WRBA business.

If you join midyear, old issues will not be mailed to you. However, you may ask to receive past issues via email in PDF format.

Send check or money order to the Treasurer (*address inside front cover*), payable to WRBA or pay via PayPal to treasurer@wrba.us.

## Advertising

WRBA News is published four (4) times per year, and is distributed electronically or via the US mail.

Rates	Dimensions	Per Page**	Per Issue	Per Year
¼ page	2" x 5½"	\$25	\$85	
½ page	4" x 5½"	\$35	\$120	
Full pg	7½ x 4½"	\$50	\$165	

\*\*based on 8x5 inch layout

### Submission deadlines

Jan 5, Apr 5, Jul 5, Oct 5

Submit advertising copy to the editor.  
Submit payment by PayPal to Treasurer.

## Member States

**ALASKA**  
Joy Journeay 907 223-1040  
4000 Truro Drive, Anchorage AK 99507  
joyjourneay@gmail.com

**ALBERTA**  
Yessy Byl, 11144 67th Street  
Edmonton AB CANADA T5B 1K8  
yessyby@telusplanet.net 780.474.8101

**ARIZONA**  
Roberta K. Schuler, 520 296-8196  
6565 E. Crimson Sage Dr., Tucson, AZ 85750  
bklassic@comcast.net

**BRITISH COLUMBIA**  
Norah Clark, 3070 Collens Hill Road  
Kelowna BC CANADA V1Z 1P5  
norah@button-shop.com 877 769-4696

**CALIFORNIA**  
Janelle Giles, Membership CSBS  
jgiles@gmail.com

**COLORADO**  
Jane Hill, 6 Purdue Court  
Longmont CO 80503-2145  
jane.e.hill@gmail.com 303.772.9248

**HAWAII**  
Don Ortwein, 808.262.7061  
515 Ululani Street, Kailua HI 96734  
donsbuttons@hawaiiintel.net

**IDAHO**  
Simone Carbonneau-Kincaid, State President  
208.667-0072  
sckincaid@gmail.com

**NEVADA**  
Gil Biggie  
9075 Wigwam Way, Reno NV 89506  
dbgb@charter.net 775.971.9538

**NEW MEXICO**  
John & Judy Harris  
P O Box 271, Mesilla NM 88046  
jiharris15@juno.com 505.526.1156

**OREGON**  
Peggy Mathes  
1040 West 16th, Eugene OR 974  
twodog@clearwire.net 541.485.1356

**SASKATCHEWAN**  
Darlene Orr, 4044 20th Street #12  
Vernon BC CANADA V1T 4E3  
d.orr@shaw.ca 250.549.1819

**UTAH**  
Barbara Halls, 2976 W 5600 S  
Roy UT 84067, 801.774.9154

**WASHINGTON**  
Dale Parkhurst, President  
11529 23rd Avenue NE, Seattle WA 98125  
dalep@gohuskies.com

**WYOMING**  
Kathy & Bob Buckardt, 807.742.7415  
4511 Mockingbird Lane, Laramie WY 82070  
bobkat1031@mindspring.com

## PRESIDENT'S MESSAGE

### WHO RAH FOR SACRAMENTO

Dear Members of WRBA:

I have mixed feelings about the name Sacramento. My grandmother came to this country around 1910 from Croatia. She would use the name Sacramento, California, in place of using the name of the Lord in vain. I don't know why. I was a bewildered little kid when Grandma was upset and waving a dishtowel and yelling "Sac-ra-men-to-Cal-i-for-ni-a"!



As time went on, so did Grandma. I got my first job and noticed another thing about Sacramento. They wanted some of my money. Not just a token but almost as much as the Lord himself suggested was to be His.

Now California has great weather. No global warming. No global cooling. Just-right weather. The down side of California is the number of silly rules and regulations they make up in – guess where?

I'll give you just one silly example. We own a rural piece of property in the mountains. It is pretty and peaceful. We thought we may someday build a house and live there, so we asked the local electric company (PG&E) how much it would cost to bring power to the property. The answer was \$20 per foot (for about a half mile) or around \$50,000. There is a local solar company who will set up a solar power system for \$25,000. Hey, we could be green and California has solar rebates!! Here's the catch, no rebates on solar unless you have PG&E. Oh, and no county building permit unless you have PG&E. I guess PG&E bought Sacramento and the county lawmakers.

So what IS good about Sacramento??? They have a button club. They have a great button club. When they hold a regional show and sale it is not to be missed. There are tons of buttons, snacks and treats and, most important, some great people who love buttons.

I suppose there are lots of great places in Sacramento, but as for me, I like the little park where the Sacramento Button Club has its meeting. I think the SBC must also appreciate WRBA because they sent a generous donation. Thank you Sacramento Button Club! See you soon at the Western Regional in Reno, Nevada.

*Tom Barrans, WRBA President*

wrba  
2013  
Oct 3-5, 2013



Treasures  
of the sea





wrba  
2013  
Oct 3-5



# Treasures of the sea

WRBA 2013 will be October 3-5, 2013, Thursday to Saturday, at John Ascuaga's Nugget in Sparks-Reno.

Room rates in the West Tower Deluxe are \$69 for Wednesday and Thursday nights and \$98 for Friday and Saturday. Rates in the East Tower Premier are \$79 for Wednesday and Thursday nights and \$108 for Friday and Saturday. In addition, the hotel charges a \$5 resort fee which provides airport shuttle, pool, fitness center, concierge, and parking. Reservation code: GBUTTONS.

WRBA 2013 is just around the corner so make your reservations now. You can call the hotel at (775) 356-3300 or (800) 648-1177.



## Judy Schwenk & Jim Nolan

5518 Sugarloaf Street  
Anacortes, WA 98221  
(360)-293-2315  
[anajamm@comcast.net](mailto:anajamm@comcast.net)

We buy any size collections.  
Approvals sent on request.  
Contact us for your button needs.



## DEALER TABLES

*by Jane Quimby*

We are accepting applications for dealer tables for the 2013 WRBA show, to be held October 3 - 5 at John Ascuaga's Nugget, 233 N. Virginia Street, in Reno, Nevada. This is the same location where the last two WRBA shows have been held. The showroom will be Thursday evening through Saturday afternoon at 4pm.

Applications can be sent to:

Jane Quimby  
34 Valley Road Ext.  
Hanover NH 03755



The table fee is \$55 for each table, with a maximum of four tables per dealer. A full deposit should accompany the application. Please **make checks payable to "WRBA"**. Also include **your name, mailing address, email address, and telephone number(s)**.

To be a dealer, you must be a member of WRBA.

We will continue to have a limit of 25 dealers at the show.

A waiting list will be kept if there are more than 25 applications.

Cancellations will receive a refund if the tables can be filled.



# BLACK GLASS FACETED BALL BUTTONS

by Joy Journeyay

I have a limited budget and really appreciate affordable buttons. I hope to sponsor button competitions featuring trays of buttons that can be bought for less than \$5 each, and often for only a dollar.

Last year I enjoyed looking through poke boxes for faceted black glass ball buttons, to see if I could put together a tray of buttons all with different facet patterns. A competition at WRBA 2013 will feature these buttons, so start searching through your collection and put together a tray!

Not only could I find 42 different patterns but I have found more than 60, and those resulted from the search at one NBS button show. I am documenting the facet designs on these buttons, so let me know if you find others. I hope you will help me find more!

I believe that the search for buttons is rewarding, regardless of their cost, and assembled button trays are inspiring. Variety can be found in the humblest of our buttons.

Black glass buttons do not scan particularly well, so this article will be illustrated with drawings of the patterns I have found to date.

## CONSTRUCTION

It is apparent that some buttons facets are molded, others are ground, and both techniques can appear together on the same button.

**GROUND FACETS:** Ground facets on buttons are characterized by distinct features. They are often slightly irregular and have crisp, sharp edges between facets. They can often have small nicks on the edges where facets meet from the grinding wheel, and many parallel minute striations across the facet surface, where the grinding medium left marks that were not polished away. The facet edges can be softened, depending upon the amount of polishing applied to finish each button.

**MOLDED FACETS:** Molded edges are more rounded, thus giving the button a softer appearance. They have uniform facet shapes and sizes, as opposed to the hand ground button facets that often show noticeable variation.



**TWO PIECE:** Many of the molded buttons appear to be molded in two halves. This is because ball shaped buttons were made in early two-piece molds, leaving a rough seam around their middle, or "waist," where the mold halves closed. The two buttons at right illustrate the tell-tale ridges of this construction method.

The maker could grind and polish the seam smooth or add a design such as faceting to cover the blemish (illustrated in "A" and "B" below). This ground area is polished on some buttons ("A"), and on others it is not and retains a dull surface created from the abrasion of the grinding process ("B").

Hand polishing can result in a facet being rubbed unevenly until it is not flat near some of its edges. In documenting the facet patterns on these buttons, allowances are made for the slight variations of hand work.



Black glass ball buttons constructed from two halves. The arrows point to the ridges where the two halves are joined while the glass is hot.

**A**  
This button's joint between the two halves is almost completely hidden by the hand grinding and polishing. Note that the facet shapes vary around the "waist" of the button, and are shiny, indicating that they have been polished. (Design #1 in this article.)

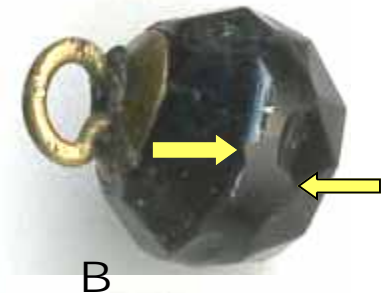

**B.** The "waist" of the button has been ground smoothly around the button, instead of into facets. It has not been polished, so is dull. The top facets are molded, and the grinding around the button eats unevenly into the top facets. Unevenness in the button bottom also results in an irregular line at the grinding bottom. (#42)



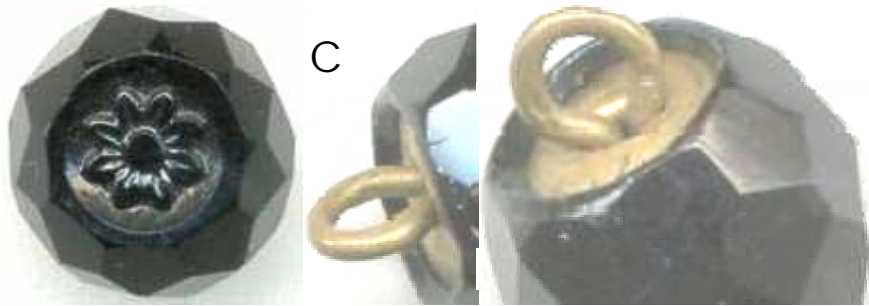

C. This faceted black glass button's loop and plate shank differs from typical construction. The plate and loop have been pushed far into the hot molten black glass, until the glass has come over the sides of the plate. The top of the button features a molded floral pattern. After the glass cooled, the top of the button was ground smooth, called a "shaved top," and the facets were ground onto the button surfaces. This button is a good example of one that combines molded surfaces with hand-ground surfaces. (Design #49 in the article.)

**SHANK TYPES**

Loop and plate shanks are the most prevalent on these buttons. Also appearing are the self shank, four hole box shank (with and without grooves), staple/antiquarian, pushed in, bridge, swirl back, and three un-named shank types. Buttons described in this article have loop and plate shanks, unless otherwise noted.

Button "D" has a typical bridge shank: a groove with a metal bar suspended across it. (Design #8.)

Button "E" has a one-piece brass curved plate and shank configuration that is embedded into the hot glass to form a tunnel for the needle. Also note that the button is constructed of two halves, mis-aligned so a larger ridge shows on one side. (Design #54.)

Button "F" ( design #40) is also a one-piece brass configuration forming the shank and a cone-shaped plate pushed deep into the hot glass. The scan shows a portion of the button that has chipped away to reveal that the brass piece continues deeper into the button.

Button "G" has the large, deep groove like those found in the bridge groove shanks. However, this shank type has a plate at the bottom of the large groove, with a loop shank.



**SQUARE OR FOUR-SIDED CENTRAL FACET**

1. Central square facet; eight sided button. Ground facets.
2. Central square with molded facets stepping down on all four sides. Bottom has no facets. Self shank.
3. Center square hand ground into four facets. The top half of the button is octagonal; the bottom has no facets.
4. Center square ground into four facets. This button is similar to #22, except that #22 has been molded or ground along the transecting facets to form a cross.
5. Four faceted center squares form a pointed top. Only the button top is faceted. Swirlback.
6. Eight sided ball button with ground facets of nearly equal area over the button.
7. Four central square facets form a pointed top. This eight sided button is found with five different side facet patterns: (a) the bottom row of facets end in a straight line around the buttons waist. (b) the bottom rows is alternating triangle facets that create a straight line at the button waist. (c) Four facet rows around the central square. All are relatively uniform in size. (d) The facets on the button sides reach nearly from button top to bottom. Three facet rows. (e) There are only three rows of facets other than the central four facets.

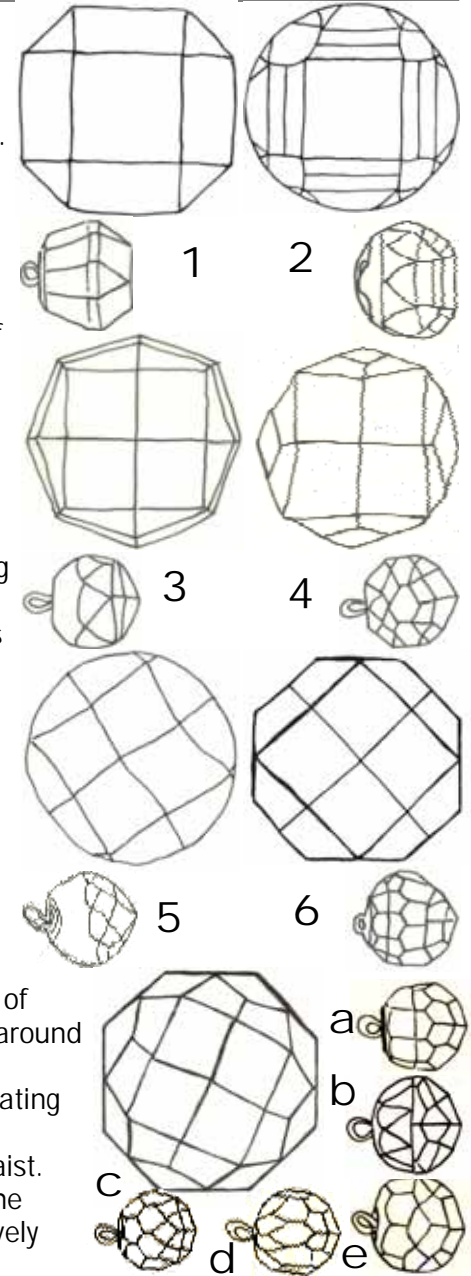

8. Center square ground into four facets. The edge of the crisscross facets continue equally creating surrounding facets of nearly equal areas. Bridge shank.
9. Center circle faceted into 12 facets with a central four-facet square. Outside of the circle, the button shoulder is faceted. Bottom half has no facets. Found in two sizes; both NBS small.
10. Very precisely hand ground button with the central four triangle facets forming a square.
11. Beautiful hand ground facets form a central square with rectangle facets reaching from each side, forming a cross. Shank is a loop and plate set inside a deep groove (see text).
12. Central square facet with ground triangle facets on each side, creating another square. Top is eight sided.
13. Central ground square facet, eight sided button.
14. Square facets surrounding the entire button. Beautifully faceted, perfectly formed button.
15. Square facets surrounding the entire button. Bottom half is smooth with no facets. Self shank.

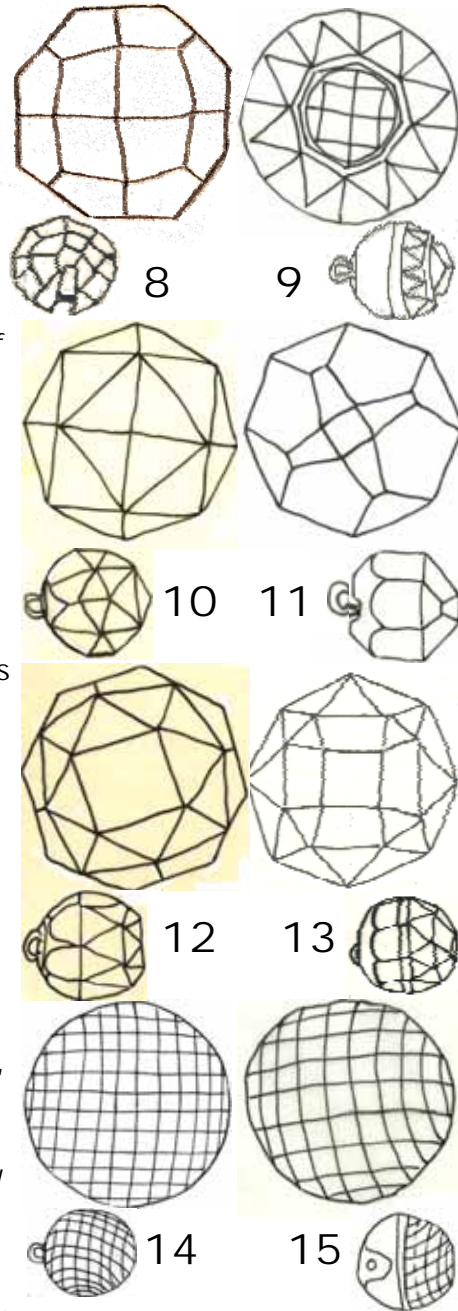

16. Central square cut into four facets, each touching a five-sided facet. Four central facets create a nearly-square pattern, but the straight sides bend towards the center.
  - (a) Both halves are decorated with molded facets.
  - (b) Hand ground.
  - (c) Top half has molded facets. Self shank.
17. Central square cut into four facets, each touching a five-sided facet. Large ground facets on the button sides form a button with an octagonal linear shape.
18. Central rectangle facet. Ground facets. Staple, antiquarian, shank.
19. Center four-sided facet, two sides being equal but not parallel. If you look at the drawing of the facets, you can see that the drawing could be cut in half in one direction to result in mirror images, but you could not cut the image in half the other way and have two mirror images. Only the top half is faceted, with the waist of the button ground and not polished, resulting in a dull encircling surface.
20. Four large modified square facets meet at the button top center, but the very top is buffed to create a small central cross. Entire button is faceted. Polished.
21. Center four square facets meet with the button top buffed along the entire facet edges to create a central cross reaching nearly to the edges of the four squares. Ground facets.

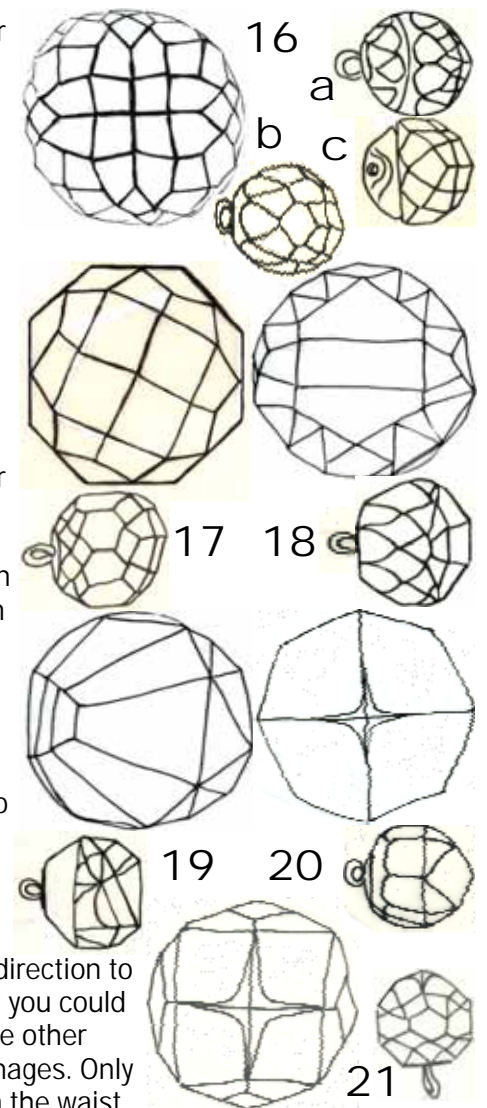

**FIVE OR MORE CENTRAL FACETS**

22. FIVE central facets form a small pentagon: a shape having five equiangular and equilateral sides. Buttons can be found constructed of both one- and two-piece molds. Facets on some two-halved buttons are molded on top with ground side facets. Other buttons have all facets hand ground.

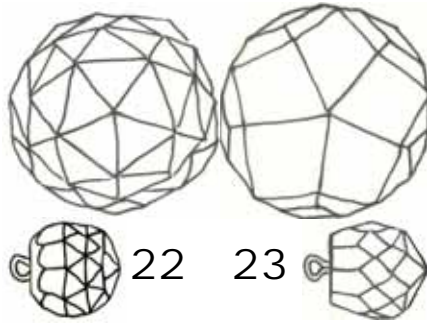

23. FIVE facets form a large central pentagon. Note that the facet edges which meet at the center top of the button do not go to the points of the pentagon as in #23, but to the sides. Hand ground, one piece.

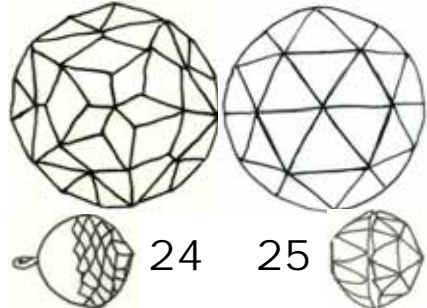

24. Five central facets form a FIVE-pointed star. The facets are molded on the top half of the ball and the bottom half of the ball is smooth.

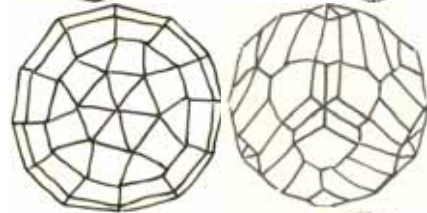

25. SIX facets form a central hexagon. The button sides are ground at the midline, making the button shape a circle. All my examples are molded.

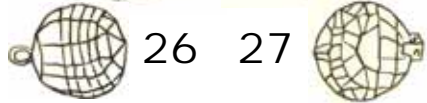

26. Twelve facets surround a central SIX-facet hexagon. The facets then proceed down the sides of the buttons in bands. The button's linear shape is a dodecagon (twelve-sided).

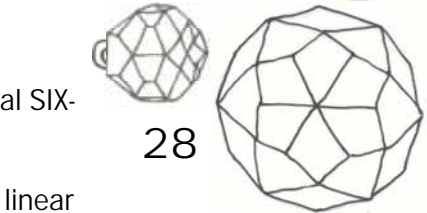

27. SIX central facets meet at the button top to form a triple shape. The button sides are faceted around three half-circle flat facets. Two-halves. Molded top facets. Four-way box shank.

28. The SIX central facets form a star with shallow points. Two-halves construction. Molded facets. Loop and plate shank is embedded in a deep groove tunnel.

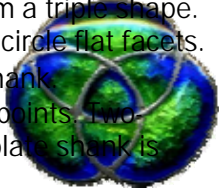

30. Central SIX facets form a pointed star, surrounded by another six facets leading to the large six facets on the sides of the button. Ground facets.

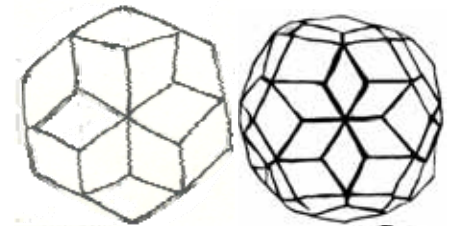

31. The central SIX facets form a pointed star. The faceting around the entire ball is nearly uniform in size. Ground facets.

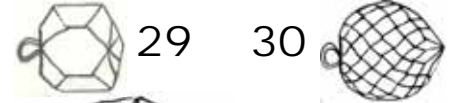

32. The central hexagon is not faceted and is surrounded by six narrow triangles alternating with six wide triangles alternating with six narrow triangles, forming a star shape extending over the top of the button and half way down the button sides.

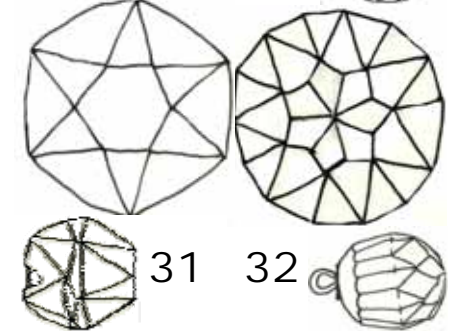

33. The central SEVEN facets form a slightly pointed star, but the faceting edges continue out on the button to form an outer seven-pointed star.

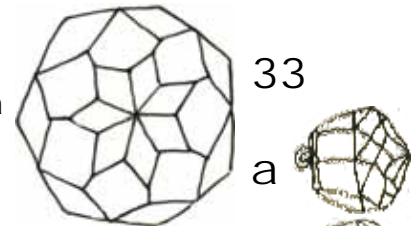

34. The top central SEVEN facets form a pointed star, and the button's linear shape is a heptagon. Hand ground facets.

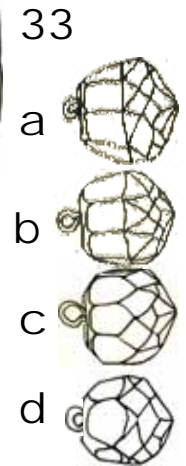

This button can be found with four different facet patterns transitioning up the sides:

- (a) The bottom row of facets end in a straight line transitioning around the waist of the button.
- (b) The bottom row of facets end in a slightly rounded top to each facet.
- (c) The bottom row of facets end in points.
- (d) The bottom row of facets are wider than they are tall, and are curved on top and bottom.



34. The central SEVEN facets form a star, just like #34, but the faceted button top leads down to round button waist. Ground facets on top half only.

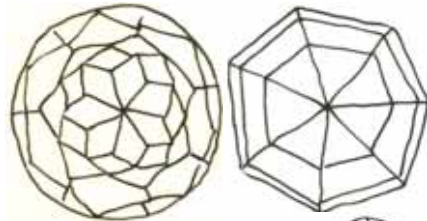

35. SEVEN central facets form a heptagon, with parallel facets working down the entire sides of the button. Ground facets.

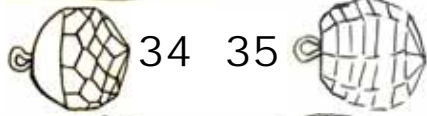

36. EIGHT central facets forming a hexagon surrounded by one row of parallel facets leading to longer facets reaching down the sides of the button to the waist. Smooth round bottom. Top only is hand ground facets.

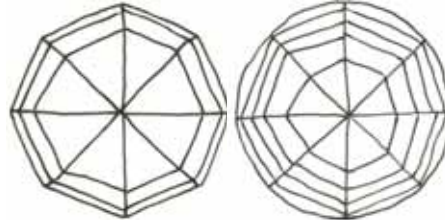

37. EIGHT central facets form a smaller hexagon than #36, surrounded by four rows of parallel facets to the button waist. Bottom half is smooth. Shank is a loop and plate set at the bottom of a tunnel through the black glass.

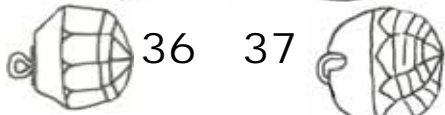

38. Central facets form an EIGHT point star. Five side variations are found, with the following surrounding the central star:

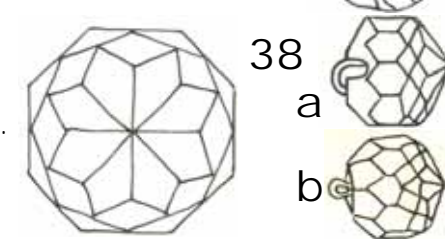

(a) Three facet rows. The bottom row is composed of pentagon facets. Loop and plate shank embedded in a deep thread groove.



(b) Four facet rows, the bottom reaching to the button edge. (c) Three facet rows. Bottom row is elongated facets. (d) Four facet rows, the bottom two are interlocked triangles. (e) Four rows. Four-way box shank with thread grooves.



39. EIGHT central facets form an eight-pointed star. Three facet rows are on the button sides. Slightly rounded octagonal button linear shape. Staple antiquarian shank.



40. The central pointed star, formed from EIGHT facets, is then surrounded by eight shallow triangle facets and two rows of straight-sided facets on the sides. The top star is molded, but the side facets are ground. A picture of this unusual shank is shown earlier in this article.

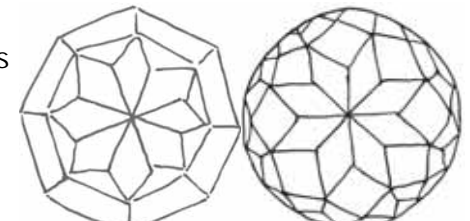

41. EIGHT facets form a central pointed star, surrounded by three rows of facets on top half only, all molded. The button waist is ground and left dull from the abrasion.

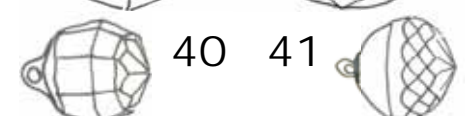

42. EIGHT facets form a central octagon. Ground around the button waist. Molded top and bottom facets.

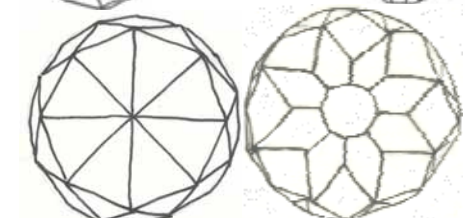

43. Octagon surrounded by EIGHT pointed facets forming a pointed star surrounded by three facet rows.

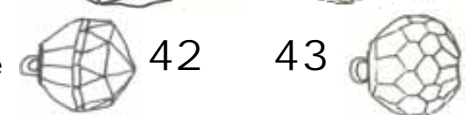

44. TEN central facets form a pointed star. Faceting on the top half only. Four facet variations can be found around the central star:



a: Almost straight button sides with no faceting complement the three rows of facets that surround the central star. Molded top. Ground sides. Four-way box shank set deeply into the button. Deep needle grooves.



b: Four rows of facets surround the star. Two halves. No faceting on the bottom half. Ground around the button waist. c: Two halves. Molded facets on top half. Smooth bottom half. Ground around the button. Four-way box shank with needle grooves.



d: Five rows of facets surround the star. Ground facets.

- 45. The central top decagon is slightly concave and surrounded by ten hand faceted triangles. Smooth button bottom. Self shank.
- 46. Central octagon is ground flat. Connecting network of facets cover button. Sides are hand ground.
- 47. Top octagon is surrounded by eight facets forming a star over the entire top.
- 48. Clear paste in the center top of a twelve-pointed star. Top facets are molded. Side facets are ground. Four way box shank.
- 49. Button top features a molded eight petal floral design. Facets cover the entire button and are ground. Shank is a loop and plate set deeply into the button, and is described in detail earlier in this article.
- 50. Central faceted floral design is molded over a textured domed top, and surrounded by ground facets on top half of button only. Shank is a loop and plate shank set into a deep needle groove.
- 51. Twelve facets form a star surrounded by three facet rows.
- 52. Center acid etched dome surrounded by a row of facets above the waist. Molding top half. Smooth bottom half. Ground around joint at the button waist. Loop and plate shank set into deep needle groove.

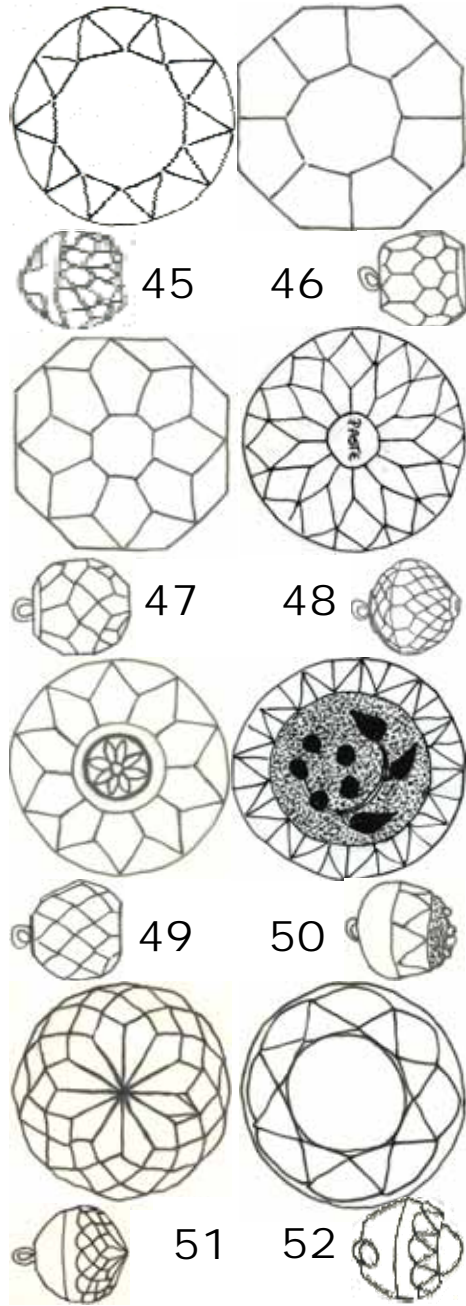

- 53. Shiny black glass ball with four touching facets ground at the top. Swirl back shank.
- 54. Five separate shiny facets on button top. Dull button surface except facets. Unique shank described earlier.
- 55. Top half of button faceted in a curved band separated by parallel grooves from concave half circles on each side. Two halves. Self shank.
- 56. Six connecting facets on the top half of the button, three on each side. Self shank.
- 57. Small network of hexagon facets across the top half of the button. Very shiny button.
- 58. Network of triangle facets across the top half of the button. Smooth button bottom.
- 59. Eight scalloped facets near the button waist and a central circle facet on the top. Ground smooth at the button waist. Self shank.
- 60. Center circle facet. Nine tiny triangle facets radiate from the circle. Nine large facets form a star. Nine larger facets form a larger star. Molding top facets with button ground around the waist. Self shank.
- 61. Eight facets surround center top octagon facet. Shiny finish.

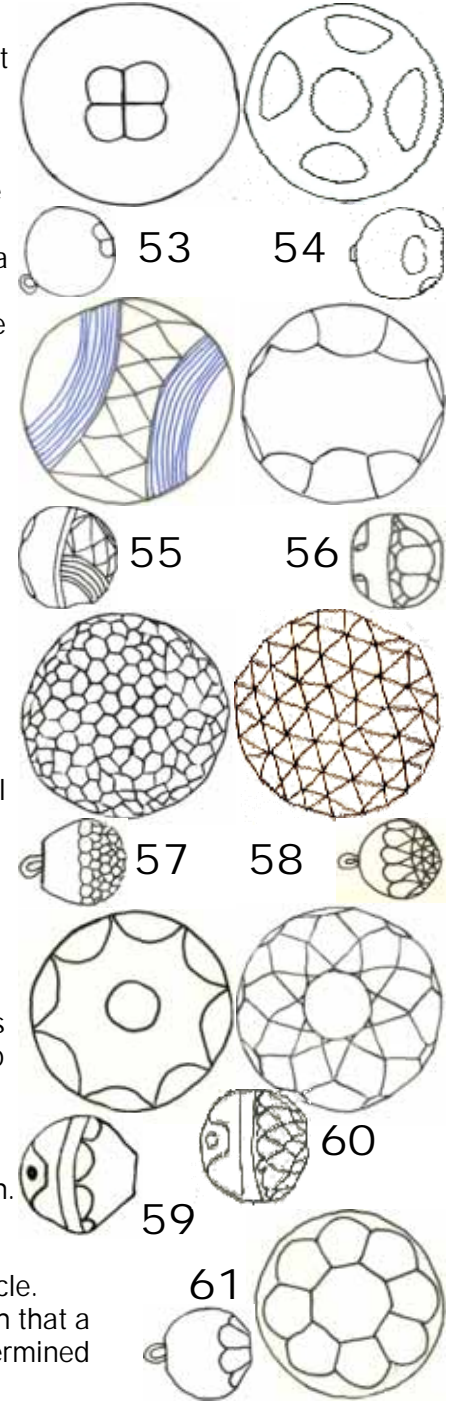

Multiple buttons were not drawn and numbered for this article. Their facets were irregular enough that a specific pattern could not be determined for the button.